

Super-Mod® Brake Only Modules: SM-20, SM-20WD (Washdown) and SM-20MB

DIMENSIONS
BACK TO TABLE OF CONTENTS
BACK TO SM PRODUCT OVERVIEW

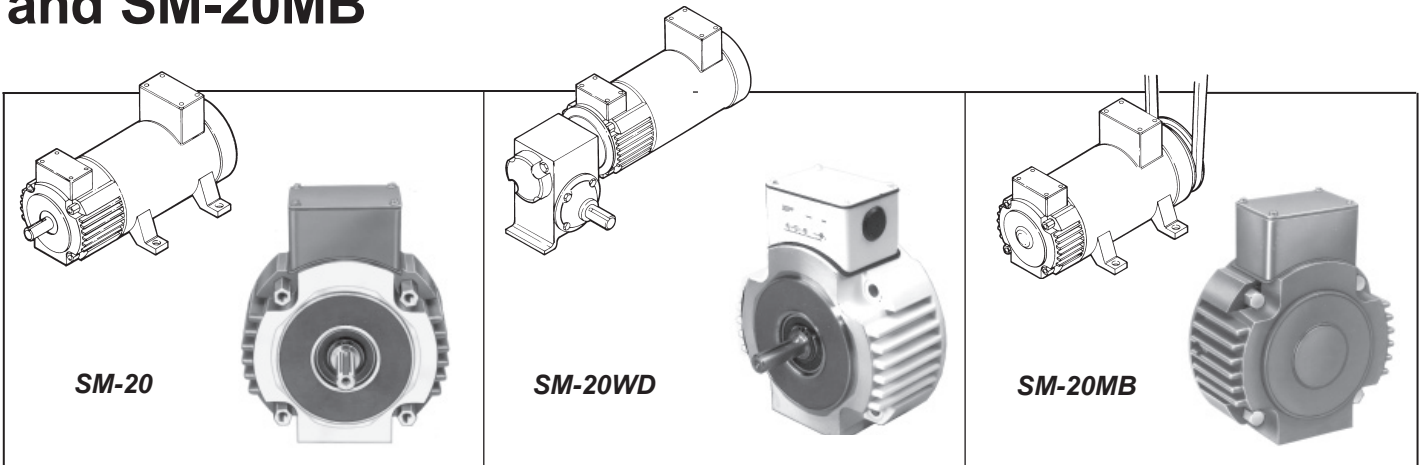

- 56C through 215TC NEMA Frame Sizes
- 16 through 145 lb-ft Static Torque; 2400 Maximum RPM
- TENV – Totally Enclosed (Non-Ventilated) IP-54 Enclosure Protection, (IP-55 for Washdown Units)
- Listed by Underwriters Laboratories, Inc., File E-71115 and CSA Certified, File LR-6254
- Power-On Brake* Engagement
- Maximum overhung load capacity is 85 lbs.

*See Catalog 200 for our complete selection of power-off "fail safe" brakes including the C-face to C-face coupler units (Series 56,700 and 87,700).

Performance Data, Ordering Information

Static Torque lb-ft	Dynamic Torque lb-ft	NEMA Frame	Hub Bore and Shaft Diameter	Model	Part Number ^①	Thermal Capacity (ft-lb/min) ^②	Wt. (lbs)	Maximum Electrical Power (watts)
16	10	56C	5/8 hub bore 5/8 shaft	SM-50-20	2-37-0561-01-A*L	5000	11	19
				SM-50-20WD	2-37-0562-01-A*L	5000	11	19
				SM-50-20MB	2-37-0561-01-X*L	5000	10	19
				SM-100-20	2-37-0561-02-A*L	5000	11	29
				SM-100-20WD	2-37-0562-02-A*L	5000	11	29
				SM-100-20MB	2-37-0561-02-X*L	5000	10	29
35	20	140TC	7/8 hub bore 7/8 shaft	SM-180-20	2-37-1401-02-A*O	5000	12	29
				SM-180-20WD	2-37-1401-02-X*O	5000	12	29
				SM-180-20MB	2-37-1401-02-X*O	5000	11	29
				SM-210-20	2-37-1801-03-A*R	7000	15	16
				SM-210-20MB	2-37-1801-03-X*R	7000	15	16
				SM-250-20	2-37-2101-04-A*U	5600	18	38
75	44	180TC	1-1/8 hub bore 1-1/8 shaft	SM-210-20	2-37-1801-03-A*R	7000	15	16
				SM-250-20	2-37-2101-04-A*U	5600	18	38
145	86	210TC	1-3/8 hub bore 1-3/8 shaft	SM-250-20	2-37-2101-04-A*U	5600	18	38
				SM-250-20MB	2-37-2101-04-X*U	5600	18	38

②Thermal capacity rating is based on ambient temperature of 70°F at 1750 RPM.

SM Brake Module Guide:

- SM-20 – Standard (direct-coupled)
- SM-20WD – IP-55 Washdown (available in NEMA frame sizes 56C-145TC)
- SM-20MB – No Shaft (end mounted)

①Example of a complete part number:

2-37-0561-01-AJL — 5/8 hub
 — 90-100 Vdc
 — Basic unit
 — 0=Standard Unit
 — 2= Without Gap Adjust

Options - Features Table

Series	Character	Description
SM-20	A	Basic unit (coupler)
SM-20	C	Basic unit plus clutch input adapter
SM-20MB	X	No shaft (end mount motor brake)

Specials available upon request.

Voltage Table

Character	Voltage
C	12 Vdc
E	24-28 Vdc
J	90-100 Vdc
N	115 Vac
P	230 Vac

Hub Size Table for SM-20's

Character	Bore	Keyway
L	5/8	3/16 x 3/32
O	7/8	3/16 x 3/32
R	1 1/8	1/4 x 1/8
U	1 3/8	5/16 x 5/32